

The “Science First” Approach to Fusion Research

B. Coppi

Massachusetts Institute of Technology, Cambridge, MA 02139

MIT Report (R.L.E.) PTP 02/04

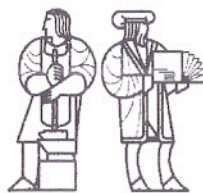

National Research Council, Washington D.C.

Massachusetts Institute of Technology

September 2002

Alcator
Machine

Alto
Campu
Torus

First
machine
without
dominant
magnetic

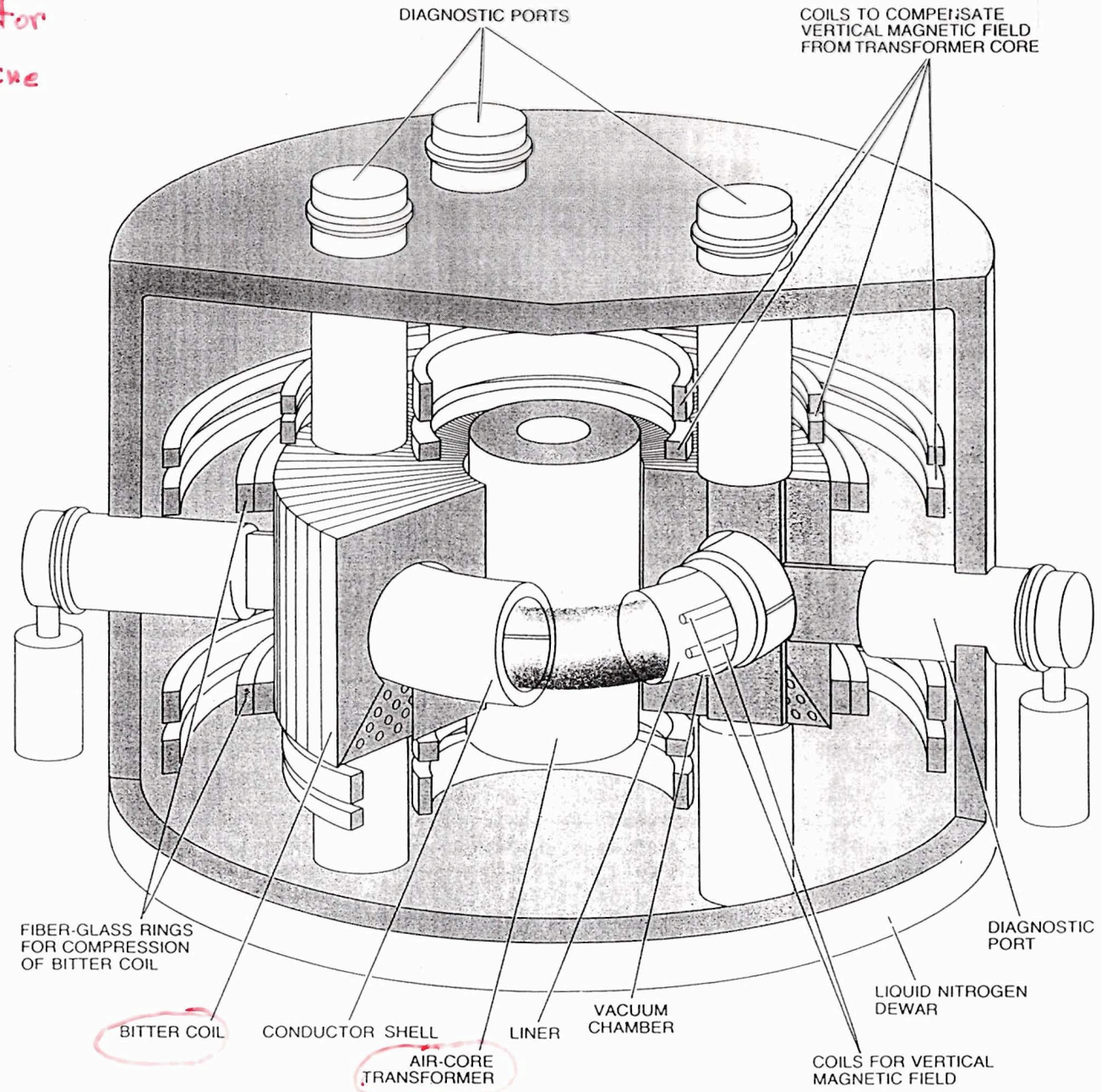

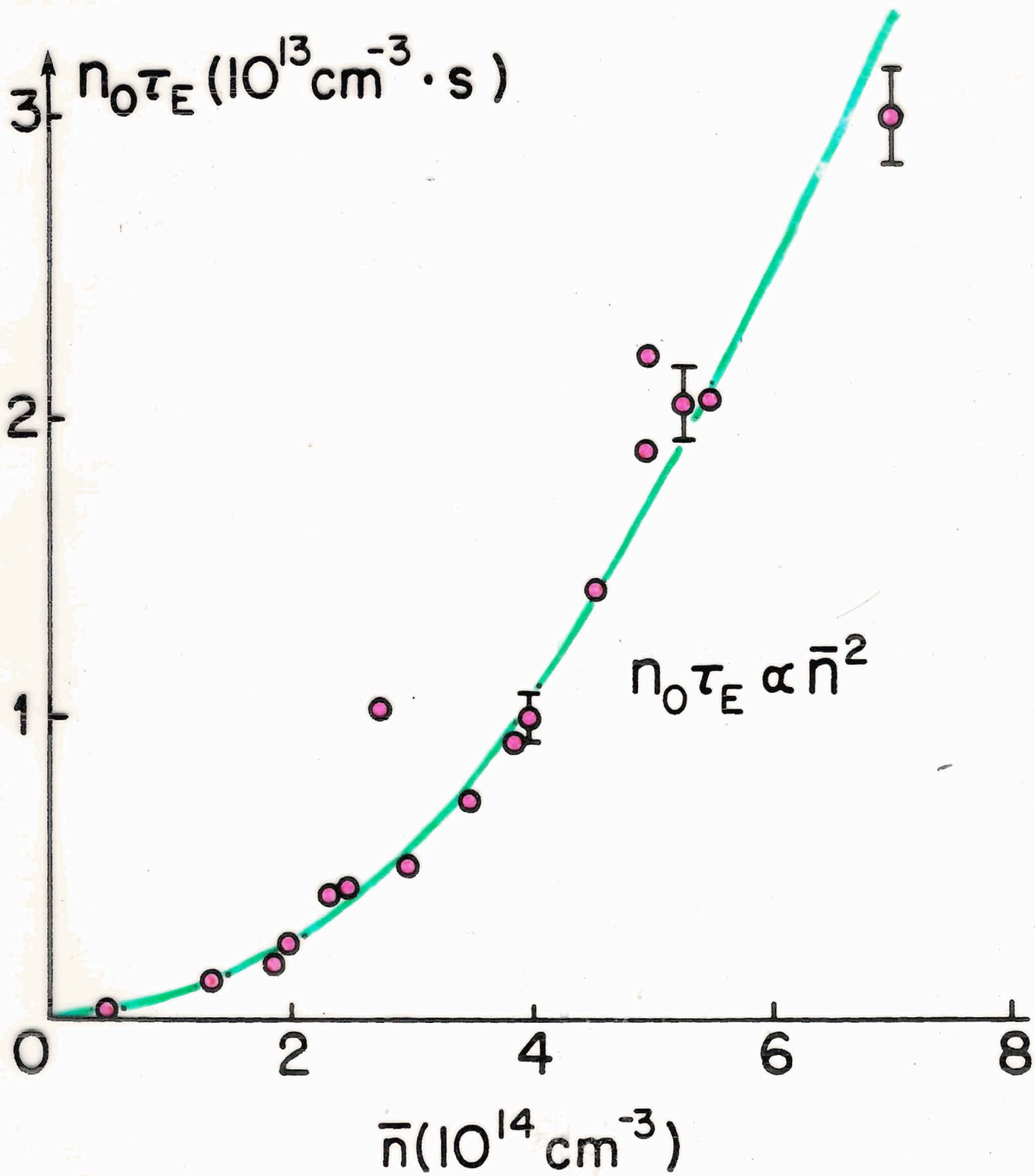

parity
 isotopic effect

Data

Points

I) *Preaching Immorality*

Good Practical Sense

(by Trilussa)*

When, at night, they spread the rumor
That a Ghost was roaming around on the castle,
All the crowd ran and, staring at it,
Fell on their knees with their arms crossed.
But an old man stayed standing, and frankly
Wanted to say that nothing was there.

Then he reconsidered: "It would be a folly to speak out.
I, without doubt, see that it is a bed sheet:
But, rather than saying the truth by myself,
I prefer to err in the company of everyone else
Therefore, it is a Ghost, without argument."
And he too went down sheep-like with the rest.

*Trilussa was a popular poet in the vernacular language of Rome in the 1800's.

II) *Preaching Morality*

As Dag Hammarskjold wrote in his
Posthumously published book "Markings:"
"You cannot play with the animal in you
without becoming wholly animal, play with
falsehood without forfeiting your right to
truth, play with cruelty without losing your
sensitivity of mind. He who wants to keep
his garden tidy does not reserve a plot for weeds.

The “Science First” Approach to Fusion Research

The “Science First” approach recognizes the fact that (meaningful) fusion burning plasmas are intrinsically self organized physical entities for which we have limited means to make reliable theoretical predictions. The first priority is, in fact, that of closing the gap of knowledge necessary to identify the defining characteristics of a working fusion reactor.

Therefore, a set of near term experiments, based on existing knowledge of the physics of magnetically confined plasmas and on technologies that do not require major new developments, is needed, which should be designed to achieve values of the “criticality parameter” K_f in the range $2/3 < K_f \leq 1$. Like in the case of particle accelerators, it is essential to devote substantial resources to technology, but this should be oriented mostly toward the actual construction of these experiments. (Here, $K_f = P_d / P_{loss}$, P_d is the power emitted as α -particles by DT fusion reactions and P_{Loss} is the rate of energy loss from the plasma.)

The problem of demonstrating and understanding controlled fusion has been recognized as one of the fundamental problems of physics. The route to a reactor through scientific understanding cannot be substituted by risky “one shot” approaches suggested by the mirage of imagined short term power station concepts. There are other areas of science that may be considered for comparison such as that of cancer research for which the idea that shortcuts could be taken, away from well proven scientific practice, cannot find credibility.

Without denying the goal to construct actual fusion power stations, I think that we should pay more attention to the near term products of fusion research. This includes, for instance, the technology of high field magnets, the development of basic plasma physics concepts and phenomena that are relevant to space physics and to astrophysics.

Looking ahead, beyond the needs of present day experiments, it is prudent to say that high field superconducting magnets will be important for future steps, as well as the development of new materials, the formulation of new structural concepts for more advanced machines, etc. Therefore an increase of funding for fusion research should include investments in these areas taking into account that the results emerging from these efforts have a high probability of being useful for other fields of science and technology.

As next steps in fusion research beyond proving ignition in a 50-50 deuterium-tritium plasma, it is possible to envision an experiment aimed at studying the burn conditions of tritium poor plasmas and a demonstration high field facility that produces more energy than it consumes. In particular, high field toroidal plasma experiments have shown that they can confine plasmas with such high densities that their reactivity can be significant even when the fraction of tritium is considerably less than the canonical 50% in a deuterium-tritium mixture.

With these perspectives in mind, my opinion is that the US should have a near term meaningful experiment on fusion burning plasmas. If this is Ignitor-like (see following figures), based on the same criteria of simplicity and stability adopted for the design of Ignitor and making use of the experience gained with the Ignitor program, and if a site with good credits is chosen, the US can certainly afford such an experiment.

In the nearer term, the US could collaborate with the ongoing Ignitor program in Italy by selecting a small group of active scientists and engineers with hands-on experience to participate in the full range of activities that are underway.

Rather than entering immediately into negotiations on ITER-FEAT and setting deadlines, I propose that the best experts in the US, on the physics and the technologies relevant to meaningful burning plasma devices, work on an "ITER-Physics" experiment suitable to be constructed by an international consortium on a long term basis. The relevant design would not include tritium-producing blankets, be of more compact dimensions than ITER-FEAT, have higher poloidal fields, higher safety factors against the main instabilities and involve drastically smaller costs and shorter construction times. Cost-benefit considerations, made on the basis of the physics parameters to be achieved with reasonably good probability, should guide the choice of the main machine components and, in particular, of the kinds of magnets that can be adopted.

Once the main characteristics of the ITER-Physics device are identified, this could be the subject of realistic and meaningful negotiations with our colleagues from overseas.

Columbus (Ignitor-like Device)

The machine would have

- The same toroidal and poloidal fields as Ignitor
- The same aspect ratio as Ignitor
- A 47% larger volume
- The same plasma current that the present ITER design would have for equal safety factors ($q_a \cong 3.6$)
- The same flexible poloidal field system as that of Ignitor, based on the DIII-D design.
- The same kind of conducting material, copper at 30 K

$R_0 \approx 1.5$ m major radius of the plasma column

$a \approx 53.5$ cm Horizontal minor radius

$b/a \approx 1.8$ Elongation of the plasma cross section

$B_T \approx 13$ T Toroidal magnetic field

$I_p \leq 12.5$ MA Toroidal plasma current

$\bar{B}_p = \frac{I_p}{5a\sqrt{\kappa}} \approx 3.5$ T Average poloidal field

If the dimensions are increased further, the magnet technology to be adopted has to be different from that of Ignitor, because of current skin effects, and be of the type (“split” toroidal magnet) proposed for the *Candor* concept. This is an experiment studied to approach D-He³ ignition conditions on the basis of present technologies and advanced (but reasonable) plasma physics notions.

EXAMPLE OF "SCIENCE FIRST" DEVELOPMENT PATH

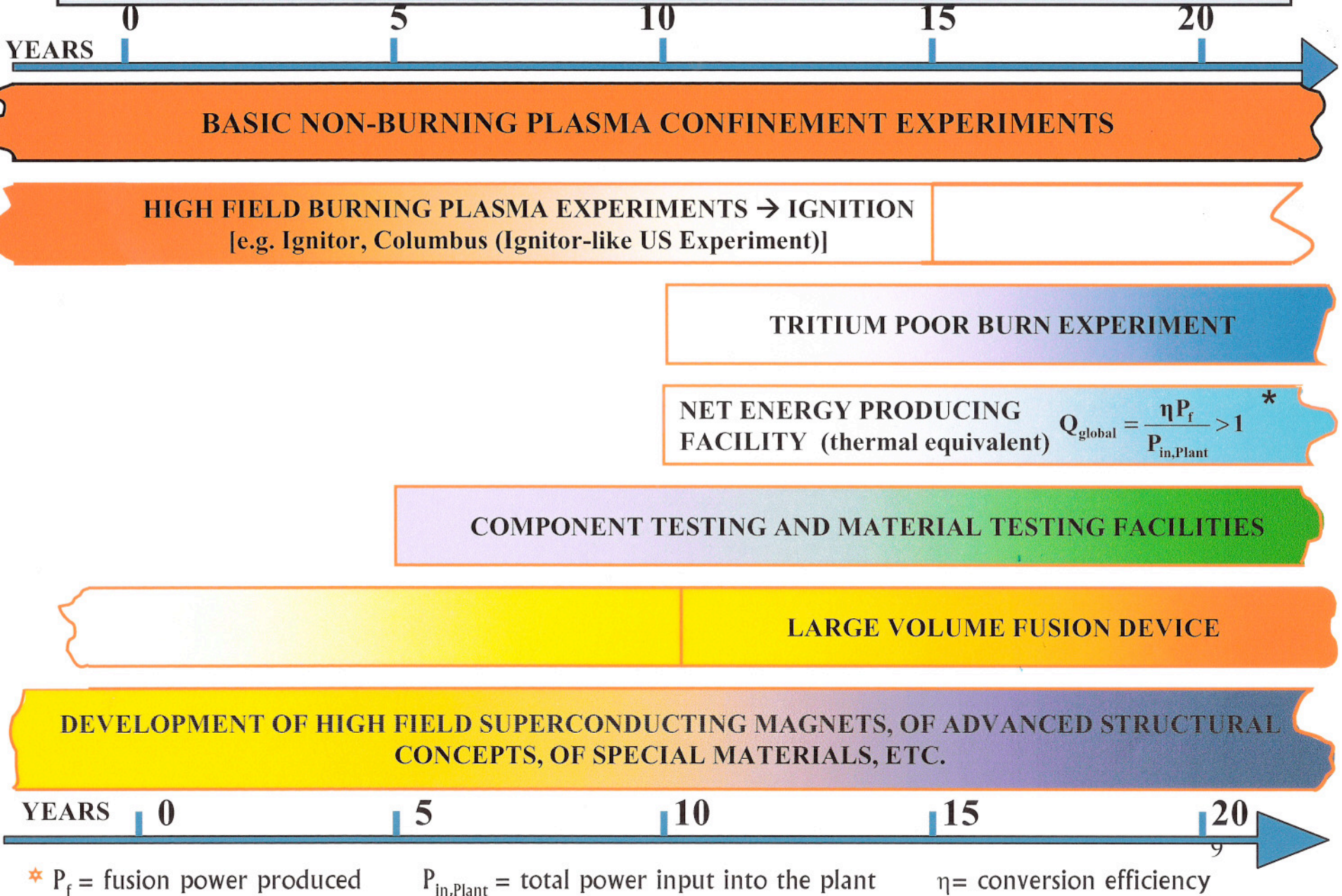

* P_f = fusion power produced

$P_{\text{in,Plant}}$ = total power input into the plant

η = conversion efficiency

IGNITOR MACHINE

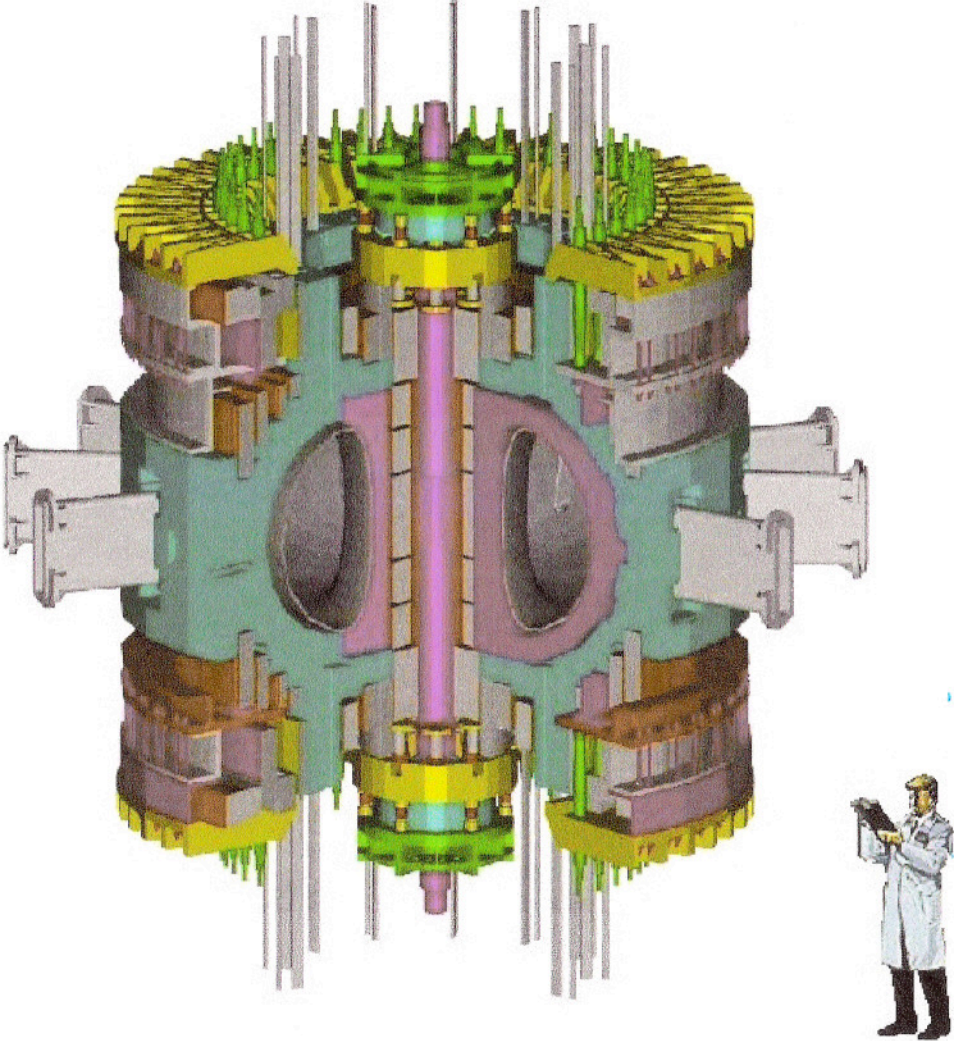

Ignitor Reference Design Parameters

major radius	R_0	1.32 m
minor radius	$a \times b$	0.47×0.86 m
aspect ratio	A	2.8
elongation	κ	1.83
triangularity	δ	0.4
toroidal field	B_T	$\lesssim 13$ T
toroidal current	I_p	$\lesssim 11$ MA
maximum poloidal field	$B_{p,max}$	$\lesssim 6.5$ T
mean poloidal field	$\overline{B}_p \equiv I_p / 5\sqrt{ab}$	$\lesssim 3.5$ T \ll
poloidal current	I_θ	$\lesssim 9$ MA
edge safety factor @ 11 MA	q_ψ	3.6
plasma volume	V	≈ 10 m ³
plasma surface	S	≈ 34 m ²
ICRF heating (70-140 MHz)	P_{RF}	18 – 24 MW
Optimal ICRH (115 MHz)	P_{RF}^{OP}	3–5 MW

Ratio of resistivity to specific heat for the copper material adopted for the toroidal magnet

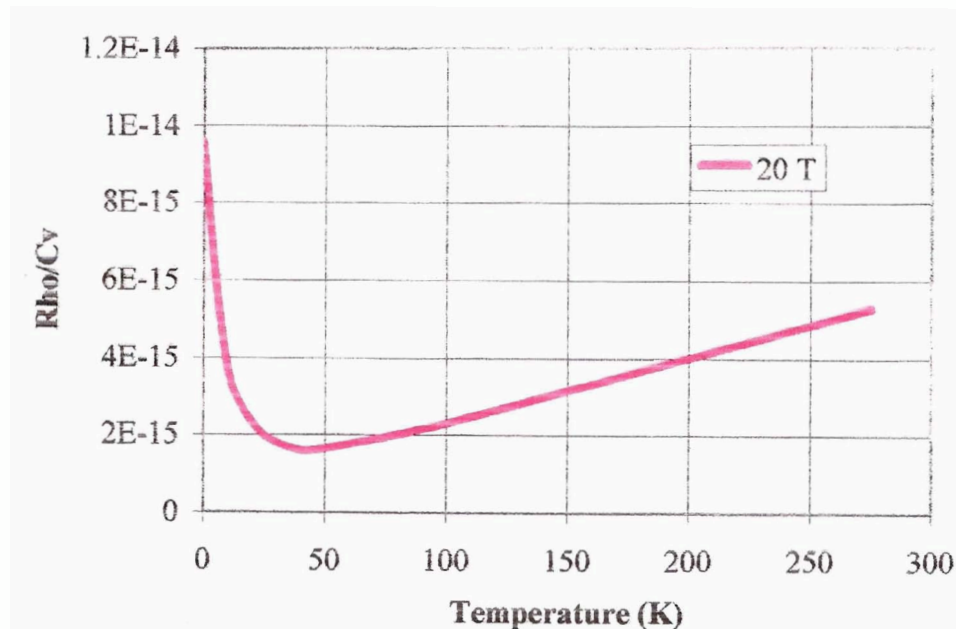

Examples of operating scenarios

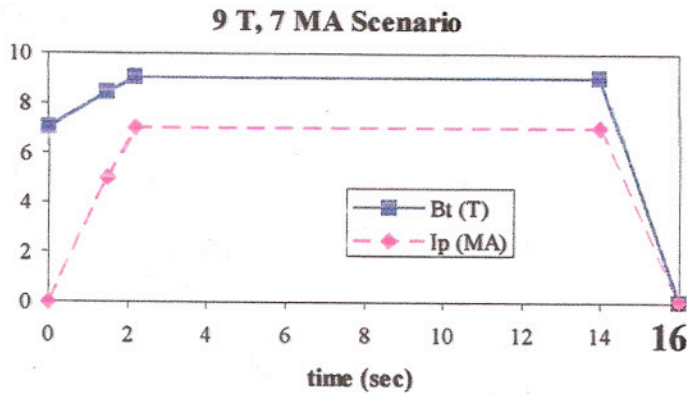
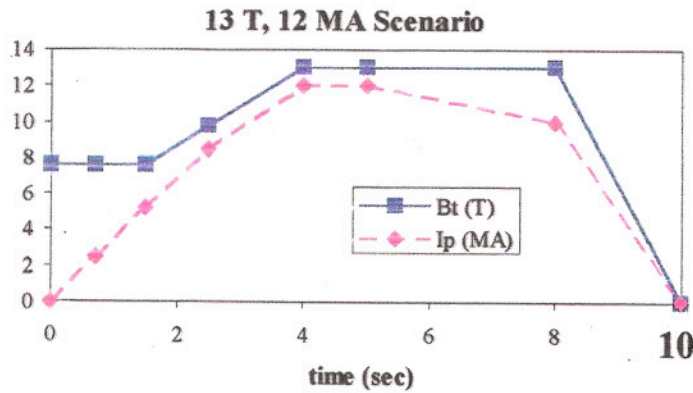
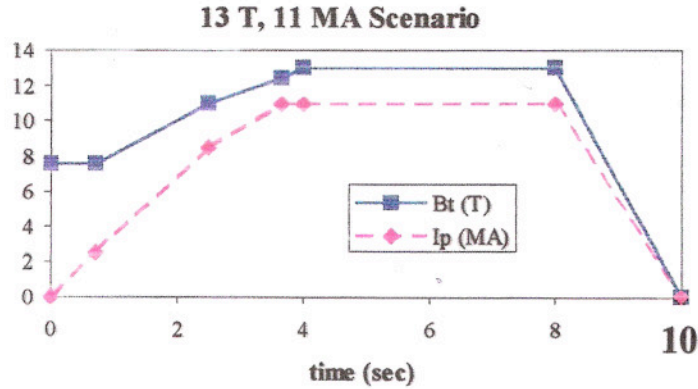

$$\chi_{\pm} = \frac{P}{P_{\text{ext}}}$$



The Ignitor strategy

Use compact, high field limiter configurations to reach ignition at low temperature, high density, and trigger the thermonuclear instability.

Low β_{pol} and a small $q = 1$ region provides a defense to ideal MHD and resistive $m = 1$ internal modes.

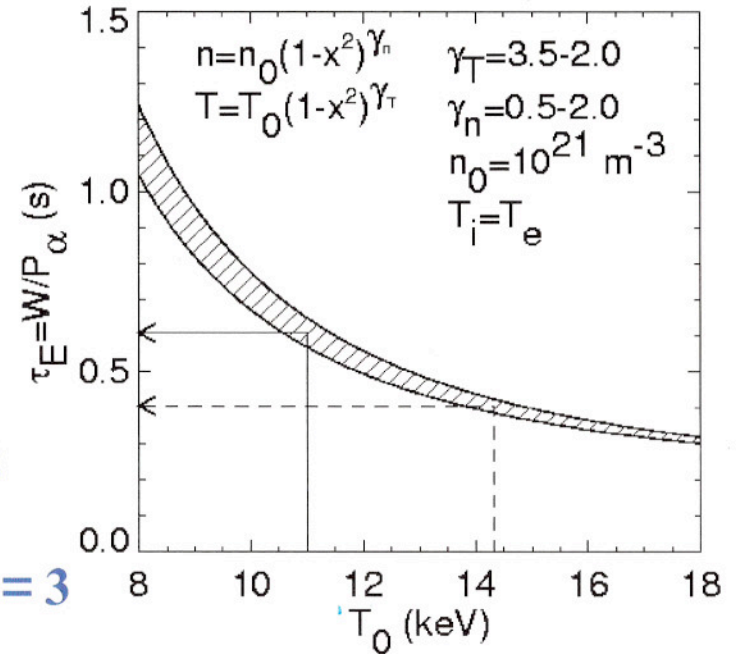
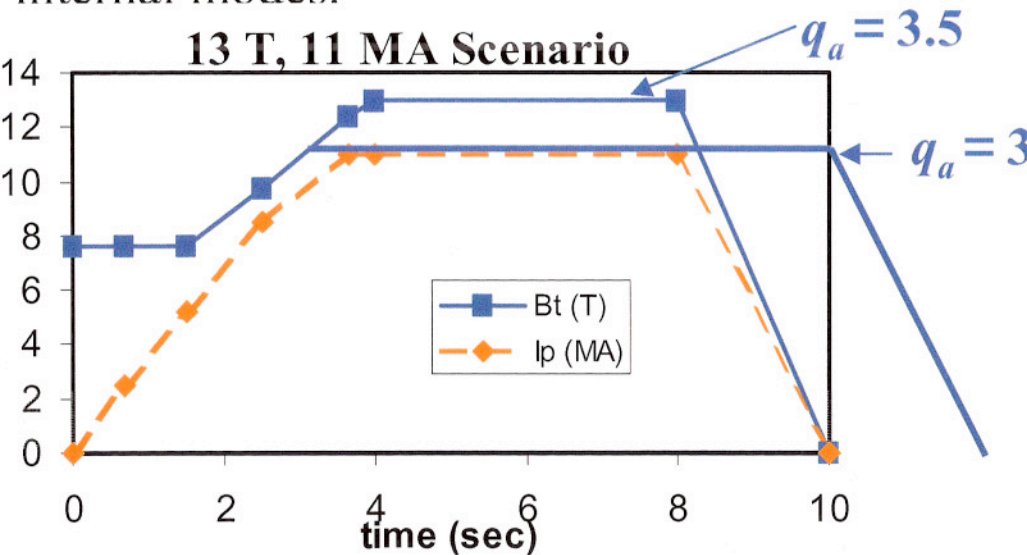

$$\frac{\rho_{bi}}{a}$$

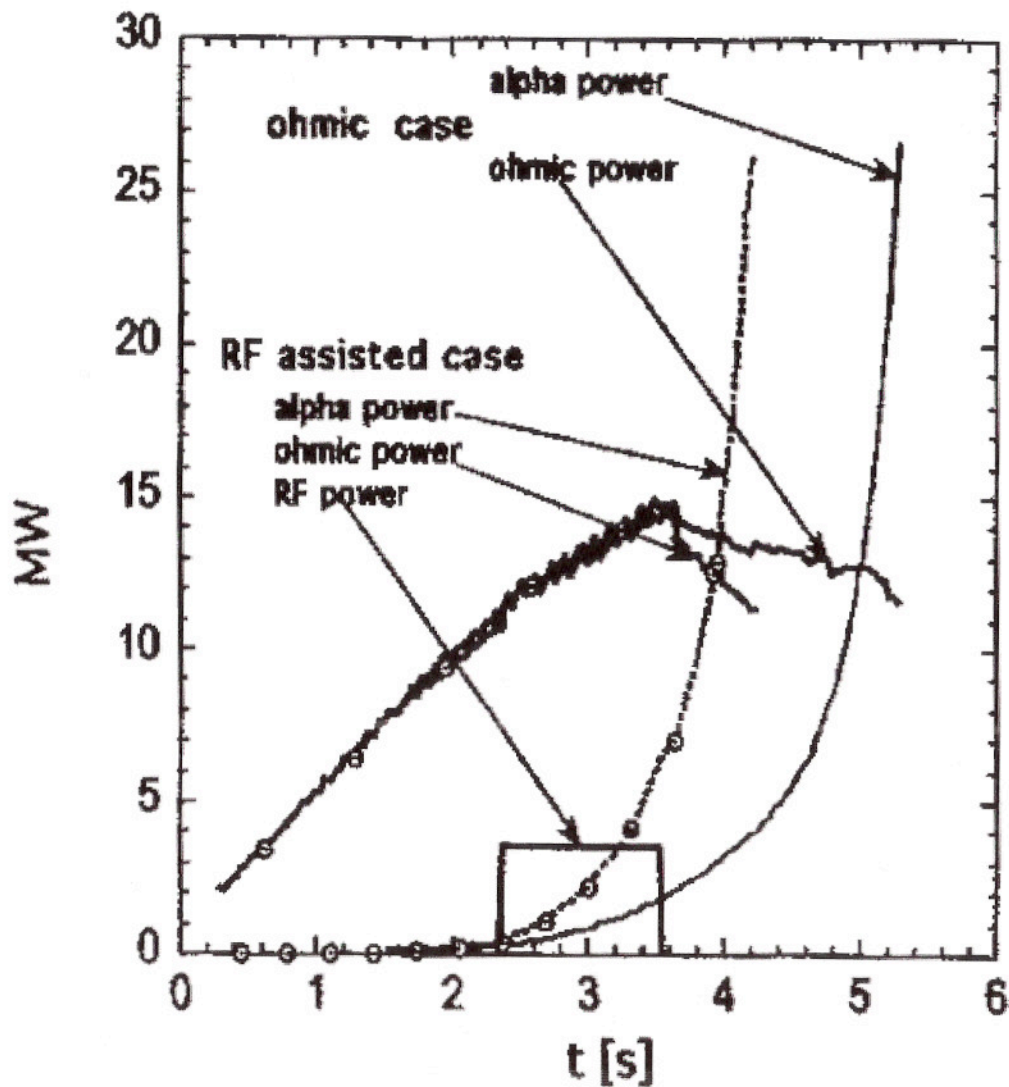

Comparison between the evolution of the powers in a purely ohmic case and a RF assisted case. The RF case shows the ignition attainment just at the end of the current ramp. (i.e. the plasma ignites before the start of the pulse flat top)

Ohmic Ignition (No RF applied)



JETTO Simulations

R, a	1.32, 0.47 m
κ, δ	1.83, 0.4
I_P	11 MA
B_T	13 T
T_{e0}, T_{i0}	11.5, 10.5 keV
n_{e0}	10^{21} m^{-3}
$n_{\alpha 0}$	$1.2 \times 10^{18} \text{ m}^{-3}$
P_α	19.2 MW
W_{pl}	11.9 MJ
$P_{OH} = dW/dt$	10.5 MW
P_{rad}	6 MW
β_{pol}, β	0.2, 1.2%
q_{VP}, q_0	3.5, ~ 1.1
τ_{E2}, τ_{sd}	0.62, 0.05 s
Z_{eff}	1.2

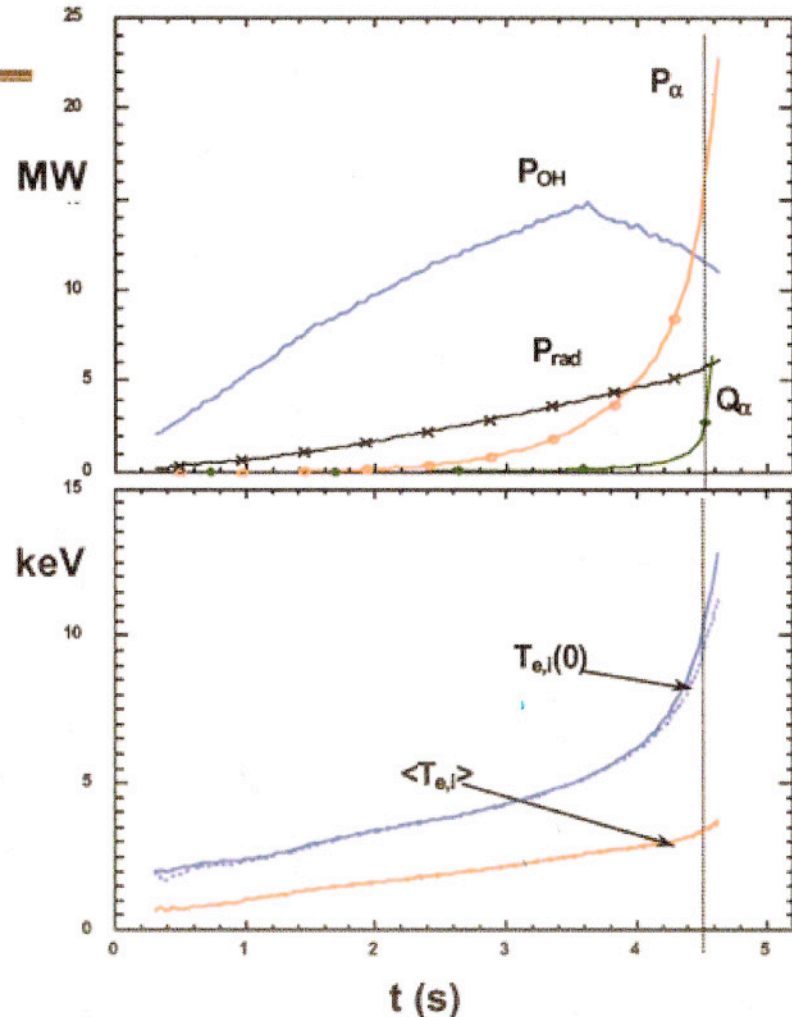

(Airoldi and Cenacchi, *Nucl. Fusion* 37,1117(1997))



IMPORTANCE OF TIME SCALE RATIOS

Relevant Parameters		ITER	FIRE	IGNITOR	ITER <u>IGNITOR</u>
		@ $q_a = 3$			
<i>Pulse flat top</i>	t_{pulse} (s)	400	20	6	66
<i>Criticality param.</i>	$K_f = P_{alpha} / P_{Losses}$	2/3	2/3	1 ^{a)}	
<i>Minor radius</i>	a (m)	2	0.595	0.47	
<i>Peak el. temperature</i>	T_{e0} (keV)	25	13	11.5	
<i>Profile param.</i>	α_T (parab)	1	1	2	
<i>Purity param.</i>	Z_{eff}	1.7	1.4	1.2	
<i>Current redistribution time</i>	$\tau_{cr}^{coll} \propto \frac{a^2 T_{e0}^{3/2}}{Z_{eff}} \frac{1}{(1 + (3/2)\alpha_{T,parab})}$ ^{b)}	118	4.7	1.8	65

a) Ignition : onset of the thermonuclear instability

b) Freidberg Report (FESAC Burning Plasma Report, September 2001)

MESSAGE: IGNITOR IS AS "STATIONARY" AS ITER ($66/65 \cong 1$) EVEN WHEN THE LONGEST PHYSICS TIME (the collisional current redistribution time τ_{cr}^{coll}) IS CONSIDERED. Note that τ_{cr}^{coll} may not be physically relevant. In fact, the current redistribution could be controlled by collective processes in the considered regimes. In this case $\tau_{cr}^{eff} < \tau_{cr}^{coll}$.

The poloidal magnetic field pressure is the driving parameter of the Ignitor design

q

$$\beta_p = \frac{8\pi p}{B_p^2} < 0.3$$

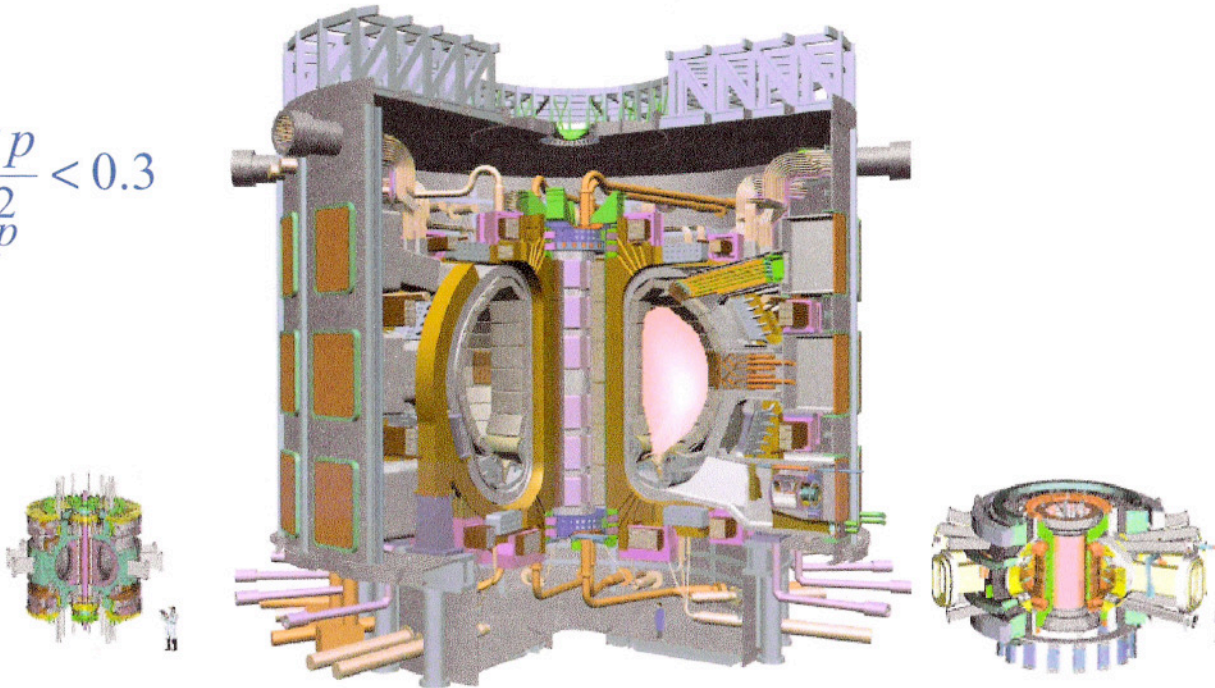

IGNITOR

ITER-FEAT

FIRE

$q_\psi \approx 3.5$

$\bar{B}_p \approx 3.5 \text{ T}$ $I_p \approx 11 \text{ MA}$
--

$\bar{B}_p \approx 1 \text{ T}$
 $I_p \approx 12.8 \text{ MA}$

$\bar{B}_p \approx 1.7 \text{ T}$
 $I_p \approx 6.2 \text{ MA}$

$q_\psi \approx 3$

lower safety factor)

$\bar{B}_p \approx 1.15 \text{ T}$
 $I_p \approx 15 \text{ MA}$

$\bar{B}_p \approx 1.9 \text{ T}$
 $I_p \approx 7.7 \text{ MA}$

q_ψ = safety factor for plasma stability I_p = plasma current

\bar{B}_p = confining (poloidal) magnetic field



MIT Plasma Science and Fusion Center
Fusion Technology & Engineering Division



IpA/R Historical Survey

$$\propto B_p$$

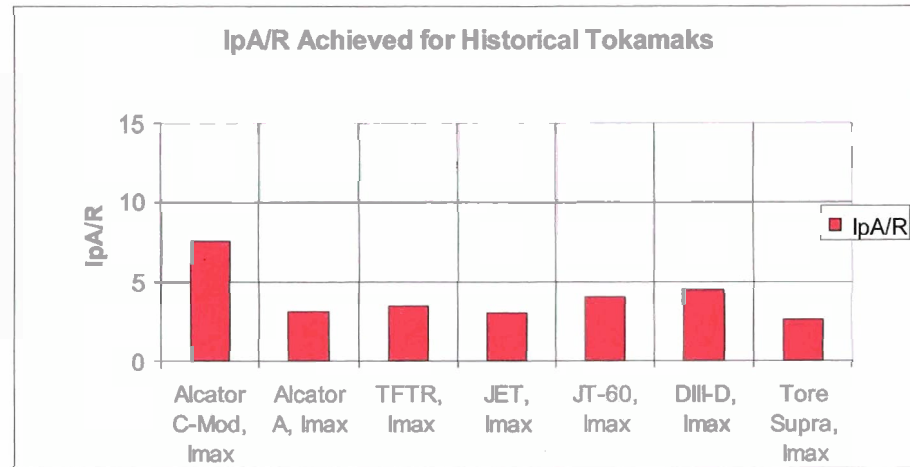
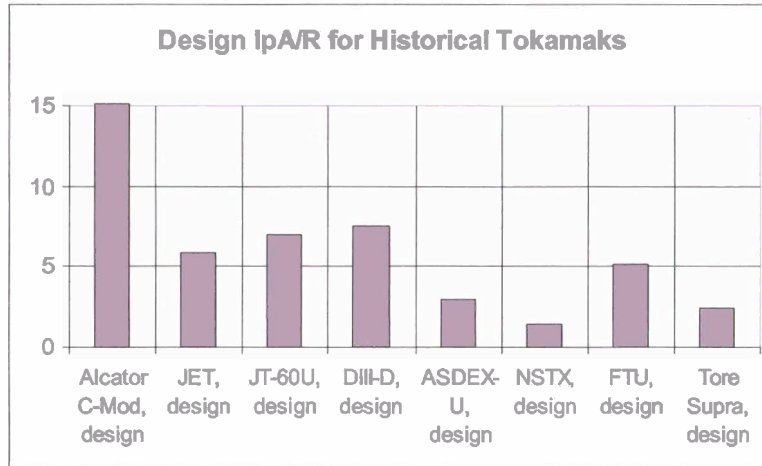

FIRE IpA/Ro 2x as high as world record

IGNITOR IpA/Ro 70% higher than other designs

FIRE IpA/Ro 2x as high as ITER

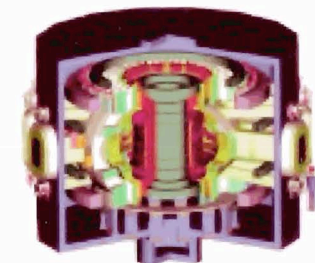
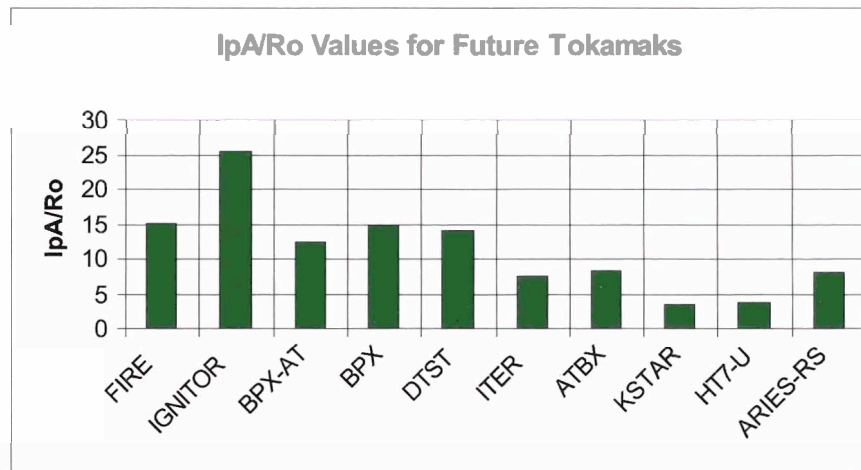

J. Schultz

Fusion Energy Relevant Levels of β/χ have been Achieved for Short Pulses

$$\beta = 8\pi \frac{\langle n(\tau_0 + \tau_i) \rangle}{B^2}$$

$$\beta/\chi_{\perp} \equiv \beta 2\tau_E/a^2$$

χ_{\perp} = diffusion coefficient (effective) for the plasma thermal energy

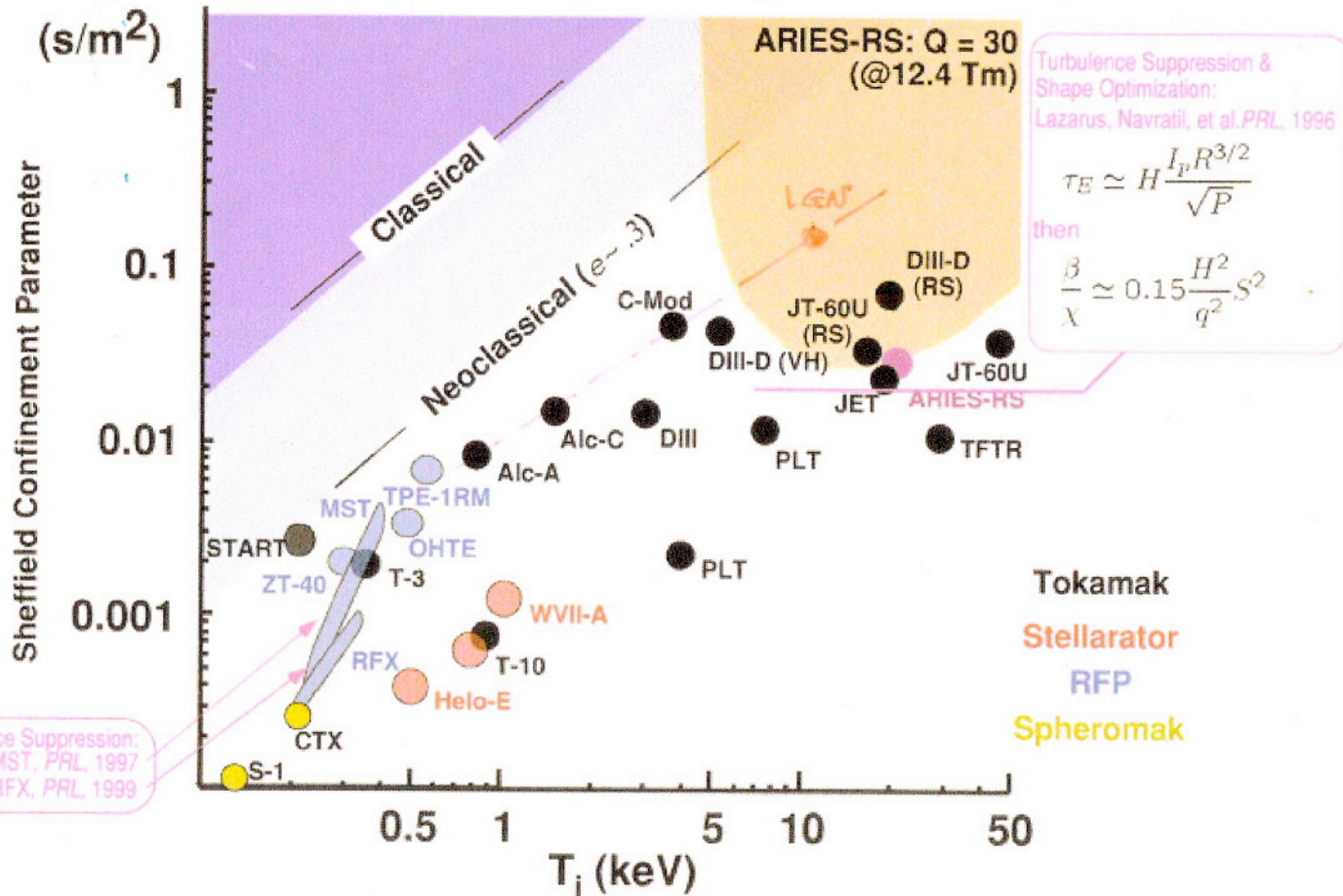

Toroidal field dependence of turbulence parameters on FTU ($a=30\text{cm}$) and T10 ($a=30\text{cm}$)

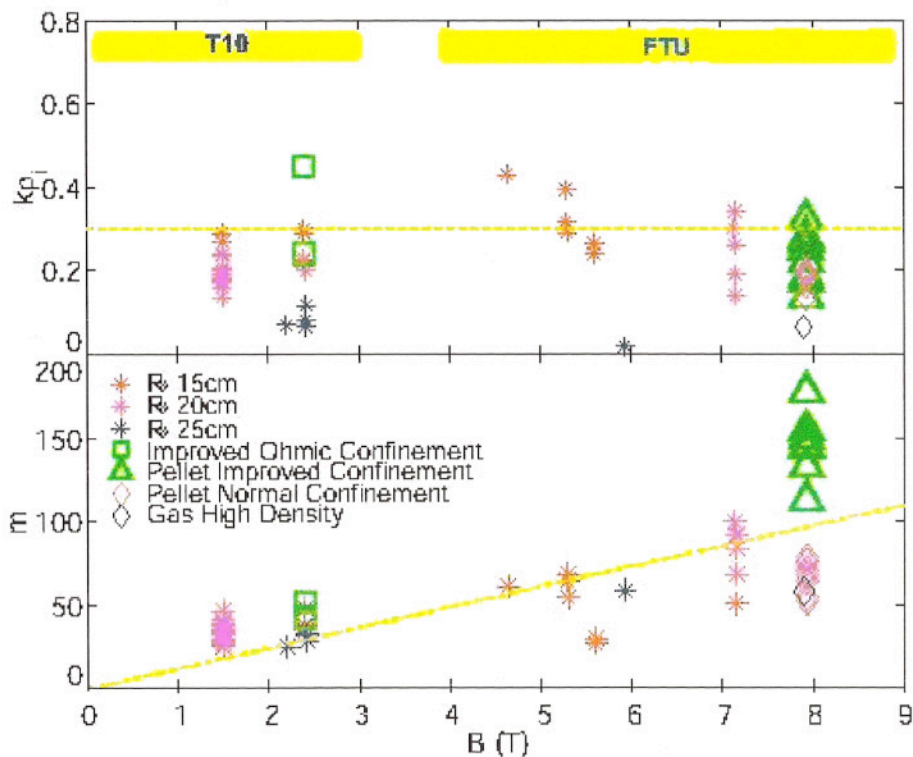

Le misure dello spettro di turbolenza negli esperimenti con pellet mostrano la differenza tra confinamento migliorato (triangoli verdi) e non (triangoli viola)

I dati si riferiscono a due scariche con pellet e mostrano l'evoluzione nel tempo del numero m e del parametro k_{\perp}^{-1} che permane al di sotto della soglia per i modi ITG in entrambi i casi

Il miglioramento del confinamento si manifesta con la presenza di celle convettive più piccole (m grandi)

I dati indicano un aumento degli m delle fluttuazioni all'aumentare di B

**Ignitor : Thermo-Mechanical analysis
of the ICRH antenna system**

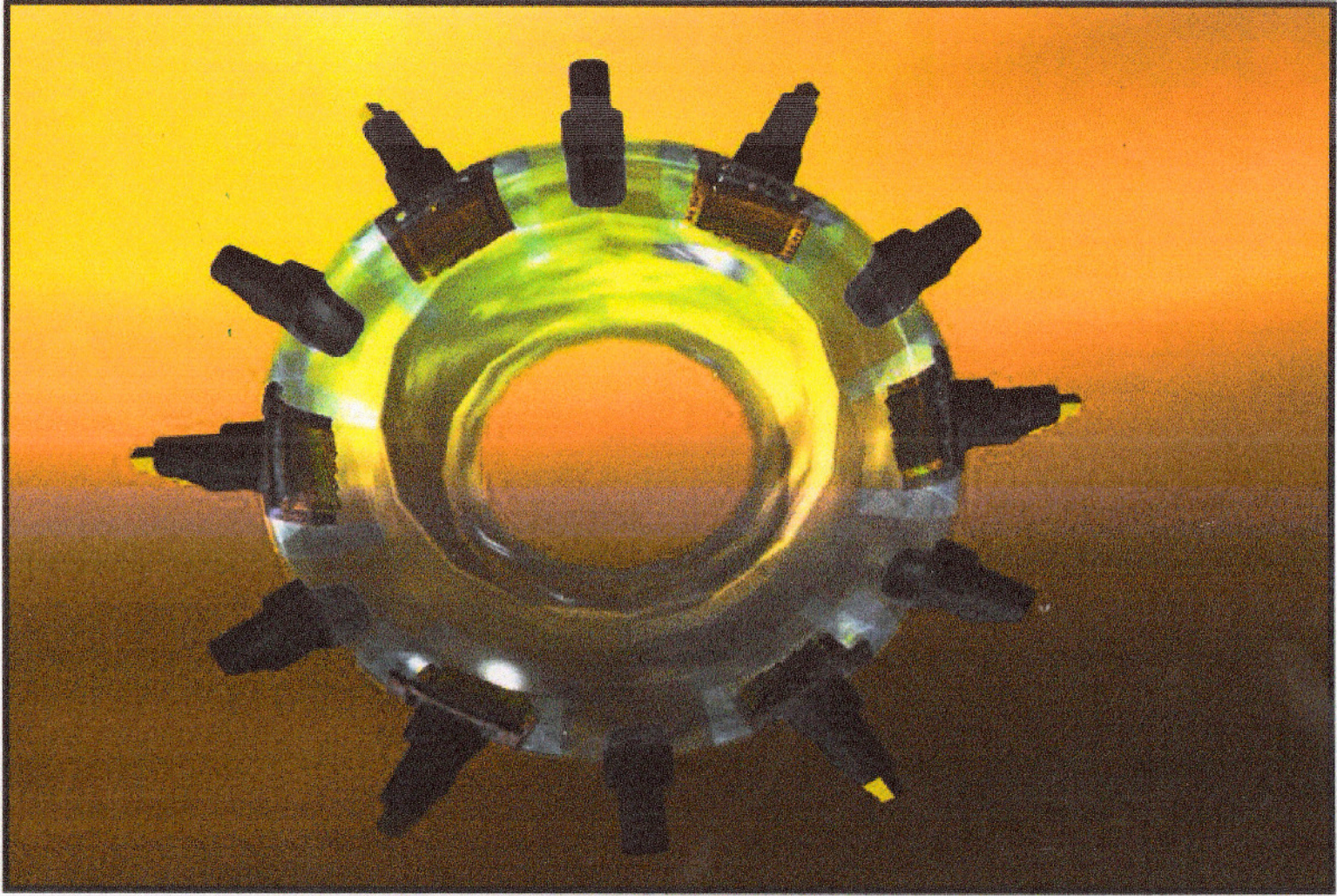

The Ignitor *R&D* program has included the construction of full size prototypes of key machine components

(Illustrations of other components can be supplied, if requested)

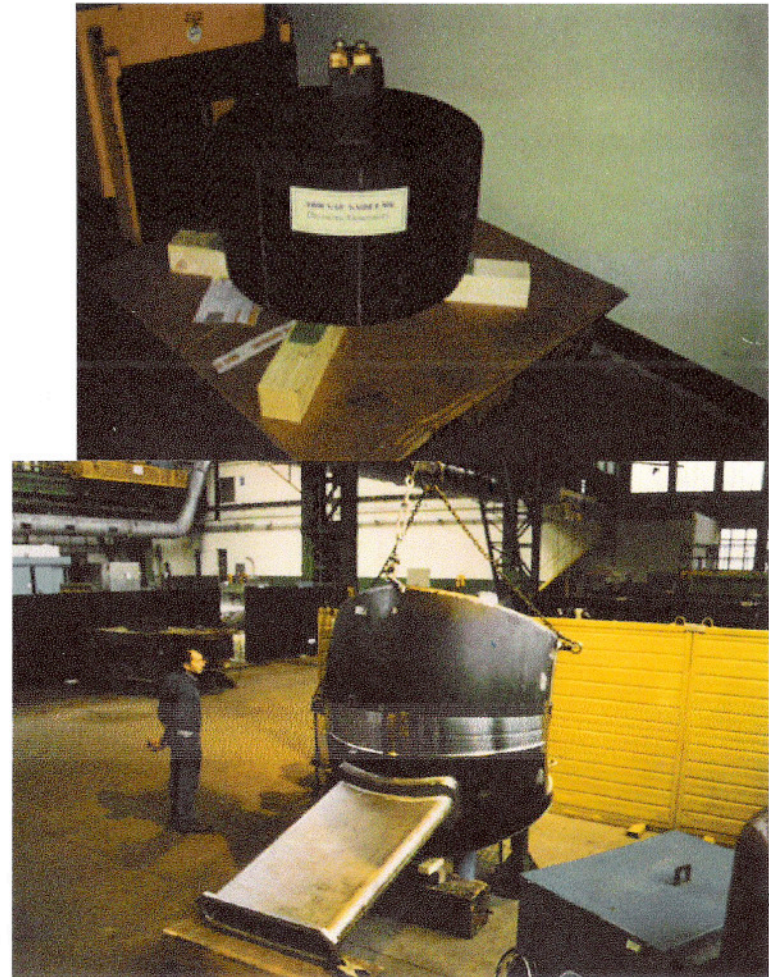

Selected site for Ignitor

Rondissone

The Italian 380 kV Transmission Grid





ENEL Center of Rondissone (courtesy of ENEL)

Plan for collaboration with Ignitor, approved by FESAC and by the Ignitor Group

C.4.3 US participation in an Italian IGNITOR

US participation in an Italian IGNITOR would be much like the traditional US collaboration on international facilities such as JET, JT6-0U, etc. The US community would identify key areas of interest and would propose to the DOE/OFES a package that would include a balance of research participation and supporting hardware. This package would be discussed with the Italian host of the IGNITOR facility and might result in a formal proposal to the OFES for funding to participate in IGNITOR in the specified manner. These perspectives are addressed in this part of the white paper.

Performance of burning plasma research by US researchers would be the primary objective of US participation in IGNITOR. US and IGNITOR organizational structures and processes must enable opportunities for the US researchers to exploit IGNITOR as a research tool, as a participant in the research activity. Elements that must be assured in the negotiations include:

- (R1) the right for US researchers to propose experiments
- (R2) US researcher participation in experiments with access to all data related to IGNITOR experiments
- (R3) proposal/development/design/fabrication/installation/operation of advanced diagnostics and enabling technology (e.g., plasma control tools) both in and beyond the baseline
- (R4) the opportunity to perform theory and integrated modeling both in design and analysis of experiments
- (R5) US participation in fusion technology activities such as the development and testing of high-field RF systems

US Contributions to IGNITOR:

US contributions to IGNITOR would be focused in areas such as baseline and advanced diagnostic systems, RF heating components, the pumping system, and the fueling system. The US contributions would be "in-kind contributions", in which the US commits to provide specific components in exchange for access to IGNITOR for associated research. The US would be obligated to provide the product irrespective of the actual cost to the US. To assure completion of scope within the budget, the US must include sufficient contingency in the budget estimates for "in-kind contributions."

Endorsement of the Ignitor Consortium Corporation by the Regional Government of Piedmont

Il Presidente

Aut. S.H.G. A.Q.A.

Torino, 31.08.2002

Spett.le
IGNITOR s.r.l.
Via Bruno Buozzi n.28
10024 MONCALIERI

Egregio ing. Boggio Sella,

ho appreso, dalla documentazione che avete inviato, della creazione della società consortile IGNITOR s.r.l., che, come da Statuto, è senza finalità di lucro ed è destinata alla realizzazione dell'esperimento Ignitor nella stazione ENEL di Rondissone (forme restando le procedure autorizzative).

Come a suo tempo discusso nell'incontro con lo scrivente, la formula della società consortile risulta essere la più adatta a realizzare questo importante progetto. La Vostra iniziativa, supportata con generosità da capitali privati, è pertanto molto apprezzata.

Come è noto, a dicembre 2001, ho inviato ai Ministeri competenti ed al Presidente del Consiglio una lettera per esprimere il grande interesse che questa Regione ha per l'insediamento di IGNITOR in Piemonte.

Con la presente, oltre all'apprezzamento della Grinta, ritengo opportuno confermare che:

- la Regione Piemonte intende procedere alla approvazione della disegno di legge 115, non appena si riserba risposta di approvazione da Roma,
- è particolarmente apprezzato l'obiettivo di creare un Centro Studi per la scienza dei Plasmi presso il Politecnico di Torino,
- siamo certo d'accordo a promuovere sia la partecipazione di Enti ed Istituzioni finanziarie regionali a IGNITOR s.r.l., sia di appoggiare l'erogazione di prestiti a fronte di programmi di ricerca scientifica realizzati nella ns. Regione,
- la disponibilità ad esaminare adeguato scaglioni di sollecito nei confronti dei Ministeri competenti e degli Enti interessati.

Distinti saluti.

va. Bruno Buozzi

Excerpts from

FROM YEARNING TO BURNING

Possible broad-brush guidelines for “burning plasma” thinking

By M.Rosenbluth (December 6th, 2000)

... we ultimately judge ourselves and are judged by others in terms of progress towards the fusion goal, both in understanding and in performance.

... the point at which science and the fusion energy goal converge is in a burning plasma experiment. It is there that we confront the unresolved issues of transport scaling, self-heating, burn control, and alpha physics, and also demonstrate that fusion energy is more than a fantasy.

The Fermi paradigm that a good scientific experiment is one with a 50% chance of success may apply here, although for such a major venture the bar should no doubt be somewhat higher, at least for meaningful partial success.

In view of past history and present it seems **prudent to look** for the **least costly** experiment **which has a high probability of success**, both in answering the most critical science issues and in serving to convince the world that fusion is a scientific possibility.

There seems to be general agreement that a Q of 10 for a few energy confinement times is needed to qualify as a convincing burning plasma experiment.

Ignitor approach

Flexibility to explore different confinement scenarios, and adequate power (including Ohmic) for extensive experiments with H or D are highly desirable. At this time it would appear that only the Tokamak is mature enough to qualify for a burning Next Step,...

There is evidently a huge cost saving in going to an inertial Cu high field machine with limited pulse length. such limited evidence as exists suggests that once a discharge has been established, its disruptivity in late flat top stages decreases radically so that very long pulse physics issues may be secondary. ... Confinement steady state, alpha slowdown, limited information on He buildup and diffusion, and some understanding of current evolution are issues determining pulse length desirability.

Ignitor approach

How does transport scale with size (ρ^*) as we approach reactor scale? We can expect much progress in theory and simulation over the next years but the problem is so complex that a benchmark at relevant size is surely required.

What effect will a high alpha population and self-heating have?... We are very short on experiments and nonlinear theory is still rudimentary. Here is the core of "burning plasma physics".

A decision on whether a divertor is necessary could have a big impact on cost. This seems indicated by cost comparisons between Ignitor and Fire designs. A higher current (and thus plausibly better confinement) can be obtained if the chamber is fully utilized, and difficult disruption engineering problems with shaping coils are avoided with limiter discharges.

We need to study in the next few years other enhanced confinement modes such as those observed with peaked profiles in high field machines. This suggests CMod experiments to supplement those underway on FTU in support of Ignitor. In accordance with the minimal cost-limited objectives philosophy I am suggesting, the non-diverted option with its modified boundary physics must be seriously considered. It may be a large cost reducer.

With the philosophy of minimal cost and risk in pursuit of the 2 key objectives, low beta appears to be a plus.... On the other hand any precise current profile control will be very doubtful although perhaps not needed at low beta.

...a strong case can only be made with regard to the toroidal , strong external field concepts, but these seem now the most promising ones.

Let's move expeditiously from Yearning to Learning!

*We should have a flame
before worrying about the
boiler (J. Dawson)*